

GC24 Drop-T Single Point Non-Locking Latch

Features

- Identical in function to locking models, but with no lock cylinder and reduced pan dimensions.
- These are used when no security is required or where free-opening is mandatory
- Easily fixed into a simple cut-out, with shaped latch tongue giving 3 mm take-up against gasketed door edge.
- Polished die cast 'hub', and neoprene seal under stainless 'cup' washer for good appearance, corrosion resistance and weatherproofing. Gasket supplied.
- Lift handle to turn latch bar, with 5 mm cam-form, adjustable through 12 mm vertically.
- Latch travels 90° from centre (rest) position against 'stops' and is 'handed' LH or RH (not reversible).
- Four holes in flanges at 7.5 mm diameter. Latch bar is adjusted by 2 x M10 nuts.

Material

- 'T'-pan: Stainless steel 304 or carbon steel to CR4
- Handle, hub and support bracket: Zinc die cast



GC24-G01505
(Single-point model
in 'rest' position)

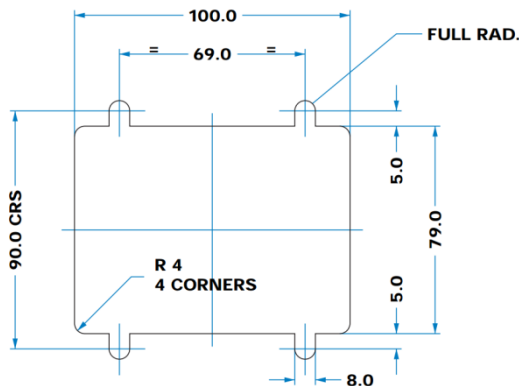
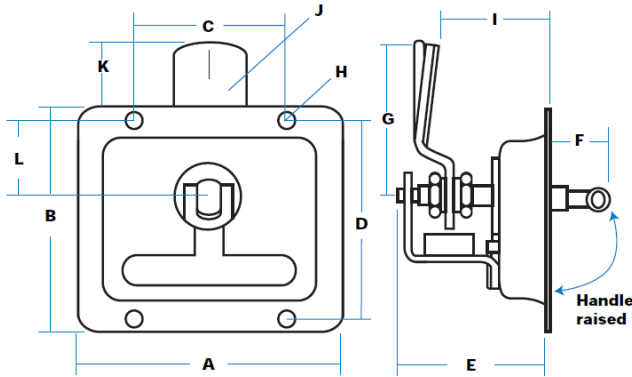

Directions of Movement

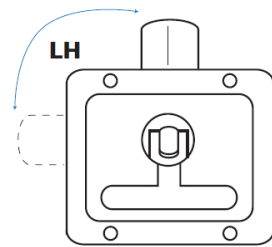

Handle turns anticlockwise to release the latch tongue

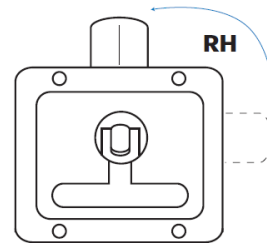

Handle turns clockwise to release the latch tongue

Part No.	Material	Type	A	B	C	D	E	F	G	H	I*	J	K	L
GC24-G01505	Stainless Steel	LH	120	102	69	90	68	30	70	7.5	43 ~ 55	30 x 5 mm deep	30	34
GC24-G01506		RH												
GC24-G01515	Mild Steel	LH												
GC24-G01516		RH												

* "I" dimension can be varied using different cam pawls

Options & Add-Ons



GC23-G01501-SF
(Drop-T with stud-fixing, also showing rubber gasket and die cast support bracket)

STUD FIXING

This is an optional feature which allows the 'Drop-T' unit to be secured from beneath, with no mounting holes, screws or rivets visible from outside.

Four weld-studs (M6 x 15 mm) are fitted to the flanges in same positions as normal mounting holes, giving better appearance, more security, and preventing entry of corrosion-causing agents.

Stud-fixing is an option on all 'Drop-T' models, including mild steel and powder coated versions.

To order, add the suffix "-SF" to our regular part numbers.

Drop-T with straight latch bar

Suffix 'A'

'I' dimension variable from 29-41 mm, 'Nominal' = 35 mm

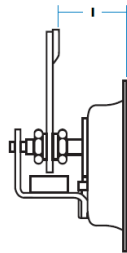

Specify LH or RH

G02068 = RH

G02069 = LH

Drop-T with long, straight latch bar

Suffix 'C'

'G' dimension is 100 mm ('K' is 60 mm)

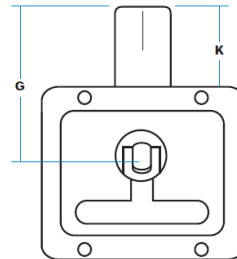

Specify LH or RH

G02431 = RH

G02432 = LH

Drop-T with 'cranked-up' latch bar

Suffix 'B'

'I' dimension variable from 21-33 mm, 'Nominal' = 30 mm

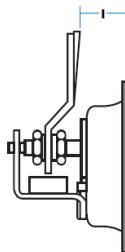

Specify LH or RH

G02070 = RH

G02071 = LH

Drop-T with straight, hooked latch bar

Suffix 'D'

'G' dimension (to hook edge) is 65 mm.

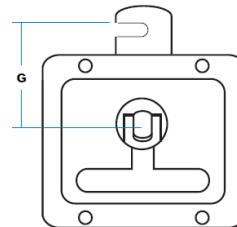

Specify LH or RH

G02058 = RH

G02059 = LH

ALTERNATIVE CAM PAWLS

Standard models use 'cranked-down' cam pawls but various options are illustrated. These are not reversible and cannot be changed after assembly. All are 5 mm thick with 3 mm 'V'-raised cam form.

Use the suffix letters shown to specify the cam pawl required.